

# Introduction to **Stock Prep Refining**

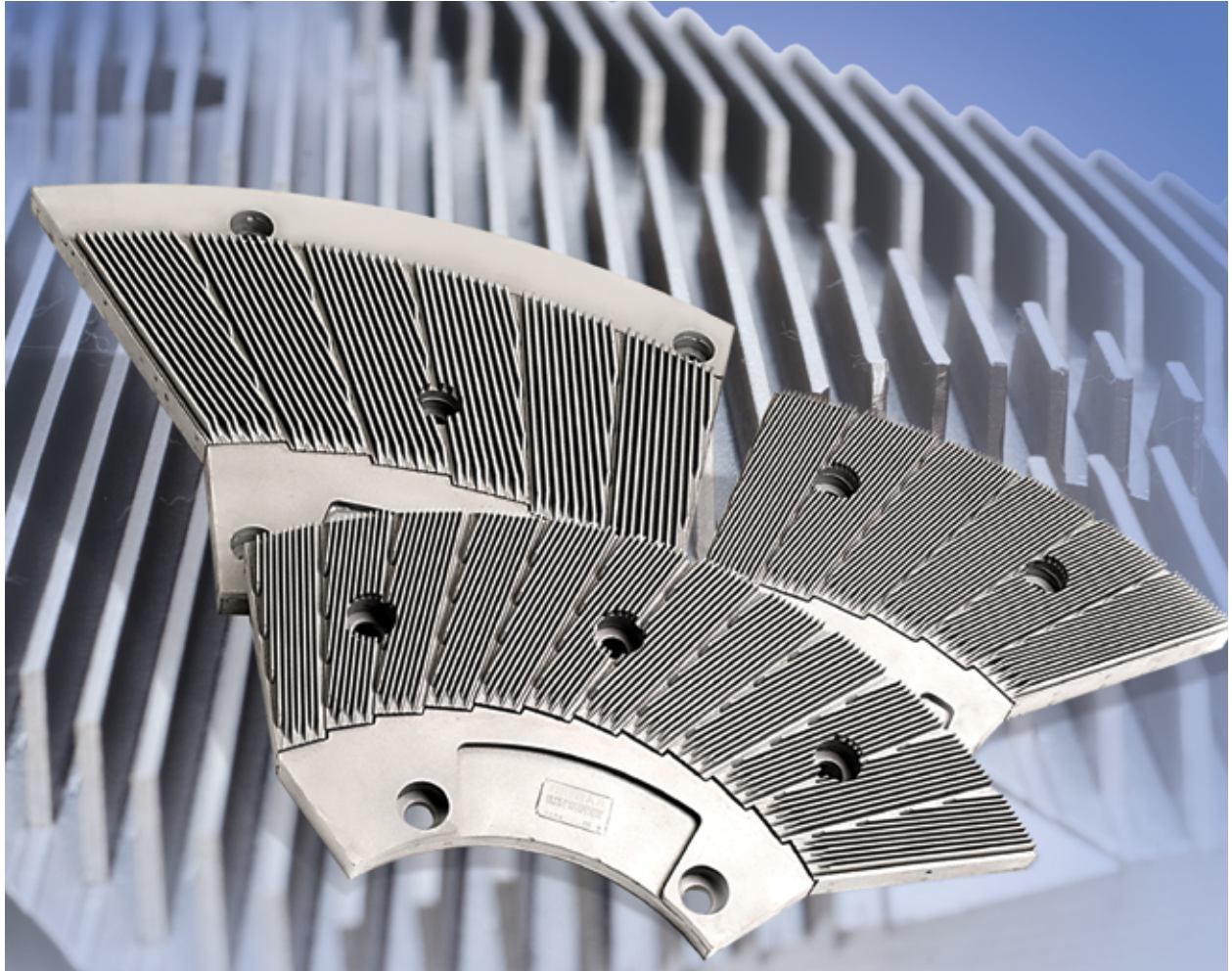

# Introduction to **Stock Prep Refining**

2016 Edition

## Table of Contents

	Page
<b>1. Introduction</b> .....	3
<b>2. Trees, Wood and Fiber</b> .....	4
<b>3. Pulping for Paper &amp; Paperboard Manufacturing</b> .....	8
<b>4. Structure of Paper &amp; Role of Refining</b> .....	11
<b>5. Pulp Quality Measurements</b> .....	14
<b>6. Paper Quality Measurements</b> .....	17
<b>7. Theory of Refining:</b>	
<b>i) Qualitative Analysis</b> .....	20
<b>ii) Quantitative Analysis</b> .....	23
<b>8. Refiner Plate Selection:</b>	
<b>i) Correct Amount of Refining (Specific Energy Input)</b> .....	25
<b>ii) Correct Intensity of Refining (Specific Edge Load)</b> .....	27
<b>9. Flow Considerations in a Stock Preparation Refiner</b> .....	30
<b>10. Conclusion</b> .....	31
<b>Appendix A – No load power in a stock prep refiner</b> .....	32
<b>Appendix B – Flow considerations in a stock prep refiner</b> .....	34
<b>Appendix C – Case study and sample calculations</b> .....	40

# 1. Introduction

The purpose of this manual is to present an easy to understand description of the stock preparation refining process. Useful methods for analyzing the process will be presented, together with guidelines for the proper selection of refiner fillings and operation of refiners.

It is difficult to learn about pulp refining without first knowing something about the overall process of papermaking. This introductory manual will provide a very brief discussion of the process of converting trees into finished paper products. To include such a broad scope of information requires a certain degree of simplification. Nevertheless, the big picture is very helpful when considering pulp refining applications, identifying process problems and recognizing the real economic opportunities of an optimized system. The refining technologist must learn how to select refiner fillings and operate refiners so as to optimize the performance of the paper being produced using available raw materials.

Among the numerous paper and paperboard grades manufactured today, the most notable are: toilet and facial tissue, paper towels and napkins, newsprint, magazine and catalog paper, wrapping paper, bag paper, and laser printer and copy paper. In addition to these commodity paper grades, there are many specialty paper grades such as coffee filters, fine writing stationary, wallpaper, and currency.

We also use a wide variety of paperboard products. These include linerboard and corrugating medium (which make up the facing and the fluted core, respectively, of corrugated containers), folding boxboard, and liquid packaging types of paperboard such as juice boxes and milk cartons.

The basic building block for all of these products is cellulose fiber. The vast majority of fibers come from trees, although some specialty grades of paper and board are produced using cotton or other non-wood based natural fiber.

There are many steps in the complex process of converting wood into paper. One of these steps is refining. Refining plays a very important role in modifying the characteristics of fibers so that they may form a sheet of paper or paperboard with a specific set of desirable properties such as stiffness, opacity, tear strength or surface smoothness, to mention just a few. In order to understand the principles of pulp refining, it is first necessary to know a little about the entire process of making paper from wood.



## 2. Trees, Wood and Fibers

**Trees can be divided into two distinctive classes:**

- 1) The non-flowering type (gymnosperms) has needle shaped leaves that stay on the tree year-round. These are often referred to as evergreens and, in the world of papermaking, they are called 'softwoods'. The principal varieties for papermaking include spruce, fir, and pine.
- 2) Trees that produce flowers (angiosperms) have broad leaves that generally fall from the tree in the autumn and reappear in the spring. These deciduous varieties - also known as 'hardwoods' - include oak, maple, birch, aspen, gum, and eucalyptus.

Although this document will focus entirely on wood based fiber, there are several non-wood plant types (e.g. reed, straw, sugar cane, and kenaf) that can also produce useful fibers for papermaking. Because these are annual plants, there exists the possibility that production of fiber from non-wood sources could become more efficient than the equivalent production from forest resources at some time in the future. However, for the present, forest resources are by far the leading source of papermaking fiber in all western countries and in most developed countries.

The two classes of trees described above - the softwoods and hardwoods - are both used to produce papermaking pulps which are similarly referred to as either softwood or hardwood pulps. These two broad classes of pulps contain fibers that are quite different in their physical characteristics. In general, hardwood fibers are much shorter and stiffer, while softwood fibers are long and more flexible. Each fiber type has advantages and disadvantages when it comes to papermaking. The selection of which to use, or what combination of the two to use, is dependant on the type of paper being produced and the required end-use properties. It is also important to realize that average fiber length and stiffness vary considerably within the broad category of either softwood or hardwood pulps; indeed, some overlap exists.

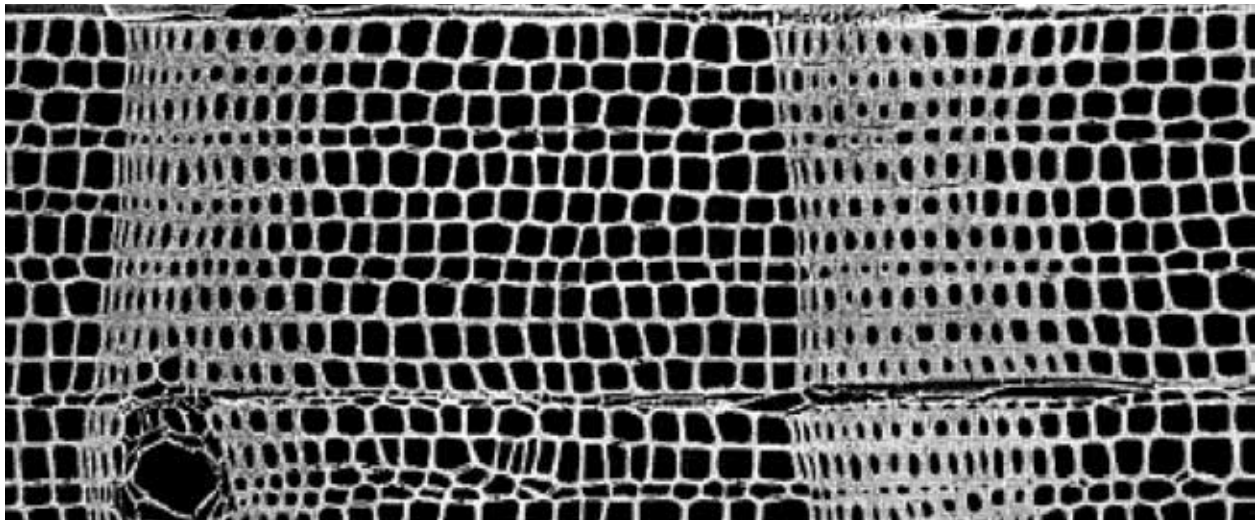

**Figure 1:** Cross-section of softwood<sup>(1)</sup>

A very simple way to examine wood structure is to study the cross section of a tree that has been cut down. The cross section of a typical softwood tree is shown in Figure 1. The main stem of the tree consists of several concentric rings. Each ring represents the growth of the tree in any one year.

The innermost rings, which are relatively dark in color, are called heartwood. The lighter colored outer rings are called sapwood, and it is in this region that water and minerals flow up and down in the tree. Between the sapwood and the bark is the cambium layer where the cells of each annual ring are spawned. This very thin layer represents the life of the tree - if the cambium layer is cut around the entire circumference of a tree, the tree will die.

A closer look at the cross section of the tree (Fig. 2) shows that each annual ring consists of several layers of cells (or fibers) which diminish in size moving outward in the radial direction through that individual ring. The larger cells with somewhat thinner walls were generated during the spring which is a rapid growth period. The smaller, thicker walled cells were generated during the slower growth summer period. These are referred to as springwood and summerwood cells, respectively. Although these two fiber groups differ significantly in terms of physical properties such as strength and stiffness, there is no practical means of separating them in the process of converting the wood into paper.



**Figure 2:** Earlywood/latewood differentiation in softwood<sup>(1)</sup>

Fibers are comprised mostly of long chain molecules of cellulose which are arranged such that the cellulose is partly crystalline. These molecules then form long parallel strands called micro-fibrils which, in turn, form long strands called fibrils. These fibrils are wound at variable angles, called the fibril angle, around the axis of the fiber. In addition to the crystalline and non-crystalline cellulose in the fibrils, there are several other polysaccharide molecules of much shorter chain length. These are collectively referred to as hemicelluloses.

Wood fibers are elongated tubular cells tapered at each end. Softwood fibers have an average length of 2.0-4.0 mm. Hardwood fibers have an average length in the range of 0.6-2.0 mm. Softwood fibers have an average width of 0.02-0.05 mm while the hardwoods have an average width of 0.01-0.04 mm. There are significant differences in relative size and average wall thickness of fibers depending on the particular species of hardwood or softwood, whether it is springwood or summerwood, how dry the growing season was, etc. Table 1 shows typical fiber dimensions for some common softwood and hardwood species.

**TABLE 1**

Wood Species	Average Fiber Length (mm)	Fiber Diameter ( $\mu\text{m}$ )	Cell Wall Thickness ( $\mu\text{m}$ )
Loblolly Pine	3.6	35-45	4-11
Douglas Fir	3.9	35-45	3-8
W. Hemlock	4.2	30-40	2-5
White Spruce	3.3	25-35	2-3
Sweetgum	1.7	20-40	5-7
White Oak	1.4	14-22	5-6
White Birch	1.8	19-30	2-4
Sugar Maple	0.8	14-30	-
Red Alder	1.2	16-40	-

The general structure of any given fiber is suitably represented in Figure 3. The cell wall of the fiber consists of an outer sheath called the primary wall (P) which is relatively thin and has no predominant fibril angle. The much thicker secondary wall is made up of three distinctive layers identified as S1, S2 and S3.

The S1 layer is relatively thin and lies just below the primary wall. The S2 layer represents most of the mass of the fiber and its average fibril angle is what determines the fibril angle properties of the fiber. The innermost secondary wall layer, S3, is thin like the S1 and lies adjacent to the hollow inner core of the cell. This hollow core is called the lumen. The cells (or fibers) in the wood are cemented together by an amorphous material called lignin. The lignin layer between cells is referred to as the middle lamella.

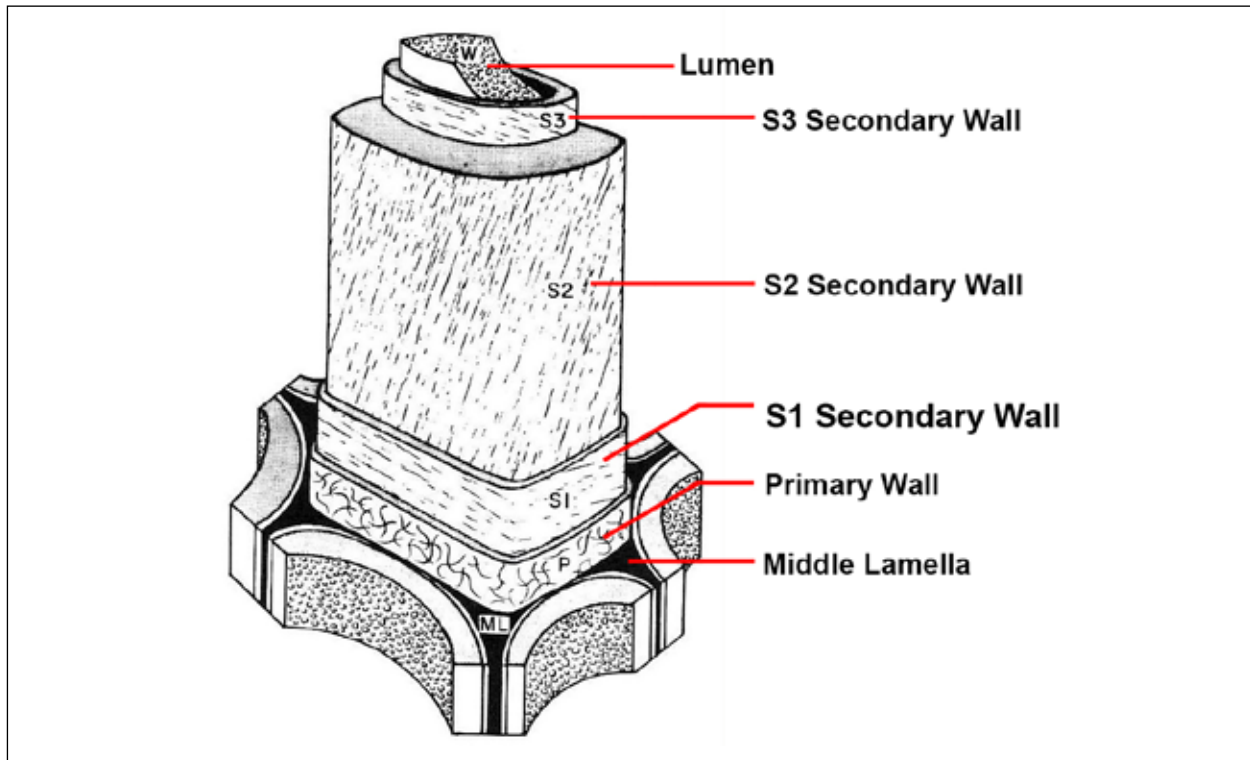

**Figure 3:** Diagram of cell wall organization<sup>(1)</sup>

In reality, the physical and chemical structure of wood is considerably more complex than the above description indicates. For example, the middle lamella contains about 70-80% lignin along with some hemicellulose and several other organic compounds. Although the cell wall consists mostly of cellulose and hemicellulose, it also contains a high percentage of lignin, particularly in the outer region of the S2 layer. While cellulose and lignin are together the main constituents of wood and are of primary concern in the papermaking process, the hemicelluloses can also significantly affect paper properties. The general composition of softwoods and hardwoods is described in Table 2.

**TABLE 2**

	Softwoods	Hardwoods
Cellulose	42 ± 2%	45 ± 2%
Hemicelluloses	27 ± 2%	30 ± 5%
Lignin	28 ± 3%	20 ± 4%
Extractives	3 ± 2%	5 ± 3%

The structural features of the two main wood types are illustrated in Figure 4. Note the general differences in cell wall thickness and fiber width between the two wood species.

For the papermaker, it is mostly the differences in fiber dimension (length, width) and stiffness that matter. For hardwoods, however, the presence of vessels is also significant. Vessels are longitudinal tubes composed of many cells connected end to end that are known as vessels elements or vessel segments. Depending on the species of hardwood and the grade of paper being produced, vessel segments can be extremely troublesome in that they contribute to print picking problems. Oak, a common wood source in the south, is most notorious for this problem.

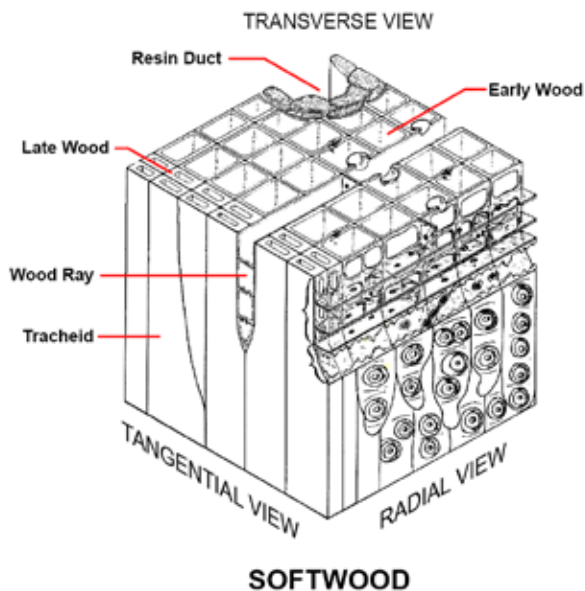

**Figure 4a:** Main structural features of softwood<sup>(1)</sup>

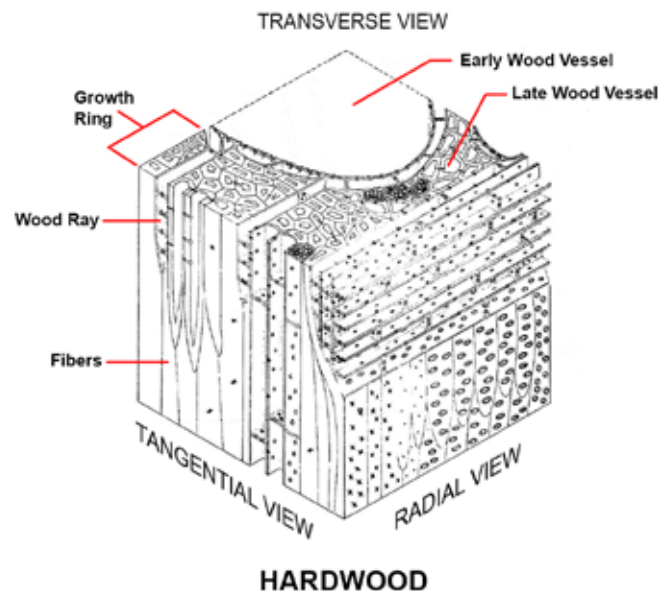

**Figure 4b:** Main structural features of hardwood<sup>(1)</sup>

### 3. Pulping of Wood for Paper & Paperboard

In order to use the cellulose fibers found in trees for papermaking, some type of pulping process is necessary to reduce the wood to its component fibers. There are two broad methods for producing pulp directly from wood: chemical pulping and mechanical pulping. Pulp from wood is often called virgin pulp, as distinguished from recycled fiber pulps that are produced from waste paper.

Chemical pulping uses some form of chemical digestion to remove the lignin that binds the fibers together in the wood. This results in a relatively complete separation of the individual fibers with relatively little input of mechanical energy. The most commonly used chemical treatments are the kraft and sulfite processes.

In mechanical pulping, a machine is used to grind or refine the wood so as to reduce it into individual fibers and fiber fragments. Very large amounts of energy are required to achieve this type of mechanical separation, and little or no lignin is removed in the process. It is important to note that, although large disc refiners are commonly used in mechanical pulping operations, the process of refining wood chips is a fundamentally different technology from the stock preparation refining which is the main topic of this manual.

**Before elaborating on the chemical pulping process and its implications for stock prep refining, a brief description of common mechanical pulping processes follows:**

#### **Mechanical Pulps**

Mechanical pulps can be produced by a variety of means. In the basic groundwood process, whole logs are pressed against large stone grinding wheels while substantial amounts of flushing water are added. The grits of the grinding stones tear fibers and fragments off the exposed surface of the log, producing a pulp slurry. The raw pulp slurry contains fibers, wood fragments, splinters, and small fiber bundles called shives. After screening, cleaning and brightening steps, this groundwood pulp is suitable for the production of many paper grades such as newsprint, directory paper, or magazine paper. Because of the limited strength of groundwood pulps, some chemical pulp fiber is added for most paper grades. A more recent development is the pressurized groundwood (PGW) process, where wood is ground at high temperature in a pressurized atmosphere. This results in longer fibers and stronger pulp than the conventional process, but with an accompanying loss in light scattering ability.

Another class of mechanical pulp is produced by feeding wood chips into large and pressurized disc refiners which defibrate the chips into individual fibers. When a pre-steaming stage is used to soften the chips prior to refining, the process is called thermomechanical pulping (or TMP). A variety of chemical additions or pretreatment can also be used, producing chemi-thermomechanical pulp (CTMP) or bleached chemi-thermomechanical pulp (BCTMP). The chemical additions may remove some lignin or other carbohydrate materials, and may reduce the required energy somewhat. However, these pulps retain the general characteristics of mechanical pulps in that the cell wall of the resulting pulp fibers does not readily swell and the fibers do not easily collapse to form dense paper.

Groundwood and TMP pulps are typically bleached using hydrosulfite and/or peroxide prior to blending with other furnish components. And both pulps can benefit from low consistency post-refining for strength enhancement and shive reduction prior to the paper machine.



## Chemical Pulps

As suggested above, the primary purpose of the chemical pulping process is to dissolve the lignin that is present in wood, and to remove the resulting by-products from the pulp. The chemistry of the process is fairly complex due to the many types and forms of organic material present in wood. The application of the technology is equally complex due to the economic advantage of recovering and reusing the chemicals and extracting available energy in the process. In the production of pulp for paper and paperboard, the prevailing processes include the alkaline sulfate process and various sulfite processes which may be alkaline, acid, or neutral. The acid sulfite process is seldom used because of the excessive damage to cellulose and the substantial removal of the hemicelluloses. The neutral sulfite semi chemical process (NSSC) is widely used in the production of paperboard for the fluted core used in carton production.

The vast majority of chemical pulps used for paper and board are produced with the sulfate process, most commonly referred to as the kraft process. Most of the information in this manual relates specifically to the kraft process, although many of the principles will apply regardless of the chemical pulping method.

The objective in chemical pulping is to remove the lignin while causing minimum damage to the cellulose and hemicellulose. In the special case of dissolving pulps which are the raw material for cellulose-based plastics such as rayon, all of the hemicellulose is removed leaving behind the alpha cellulose. For many papermaking applications, however, the hemicellulose constituents play an important role in providing strength in the sheet and it is therefore desirable not to remove them.

The dissolving of lignin begins in a hot, pressurized digester vessel as the wood chips absorb the solution of chemicals called the pulping liquor. The hollow lumen of the fiber acts as a conduit for the liquor, just as it did for the sap of the original tree. The liquor passes through the microscopically porous cell wall and quickly attacks the lignin rich middle lamella that holds the fibers together in the wood. The lignin contained within the cell wall of the fiber is more resistant to attack and is more slowly dissolved by the pulping liquor. If the pulp is to be used for linerboard or for some other unbleached paper or board grade, it will be washed to remove residual liquor and then sent to the stock preparation area for refining. In the case of bleached paper or board grades, most of the residual lignin remaining after pulping will be subsequently removed in the bleaching process using oxygen, chlorine dioxide or peroxide, either alone or in combination. The washed and bleached pulp is then ready for stock preparation refining.

## Secondary Fiber

Virgin pulps are not the only direct source of wood fiber for papermaking. Recycled paper and paperboard represent a very large percentage of the papermaking fiber used in Europe, North America, and around the world. A great advantage of recycled fiber stems from the fact that the process of reducing the wood to pulp has been previously accomplished, and it can be easily reslurried in water and immediately available to the paper machine. The primary disadvantage stems from the fact that the recycled paper or board contains a variety of fiber types, minerals, chemical additives, contaminants and printing ink. It is very difficult to maintain strict control over the properties of the paper produced when the raw material is so highly variable. Nevertheless, more than 30% by weight of the annual production of paper and paperboard in the United States consists of secondary fiber. Modern recycling mills have very sophisticated systems for the removal of contaminants and ink, and they can produce high quality pulp for many paper grades. Because recycled pulps contain a mixture of fibers (e.g. hardwood and softwood fibers, chemical and mechanical pulp fibers) and they have already been exposed to some amount of refining, selection and specification of refining equipment for secondary fiber plants requires special consideration. It is sufficient to recognize that practically all of the fibers that are present in recycled paper and paperboard were originally produced from wood, and the fiber characteristics of the recycled pulp will generally reflect those of the original wood species and pulping process.

While virgin pulps can be generally divided into the two classes described above, i.e. chemical and mechanical pulps, there are in fact several intermediate processes. Table 3 lists several of these processes together with their approximate yield.

**TABLE 3**

Pulp Type	Yield
GWD & RMP	93-98%
TMP	94-96%
CTMP	85-94%
Semi-Chemical	65-90%
High Yield Kraft	55-65%
Bleached HW Kraft	48-50%
Bleached SW Kraft	42-45%

Yield represents the percentage of the original dry substance of the wood that remains after pulping. For yields below 60% or so, enough lignin will have been removed from the cell wall to permit the wall to absorb water readily and to swell. At higher yields, cell wall swelling is limited. Fiber swelling and flexibility will be discussed in more detail in the following section on paper structure and the role of refining.

## 4. Structure of Paper & The Role of Refining

Paper is a tangled web of fibers. The fibers are more or less lying in a flat plane, and they are attached to one another at the many points of contact that occur wherever one fiber lies across another fiber. The strength of paper is largely determined by the strength of the attachments at these fiber crossing points. While it is true that strength of the individual fibers can also be a factor in determining the strength of the resulting paper, it is often the case that paper fails when the fiber-fiber bonds fail.

The linkage that occurs at the fiber crossing points of paper is made up of hydrogen bonds which are formed between corresponding points on two cellulose or hemicellulose molecules when an interconnecting water molecule is removed by drying. A representation of this type of bond in cellulose is shown in Figure 5.

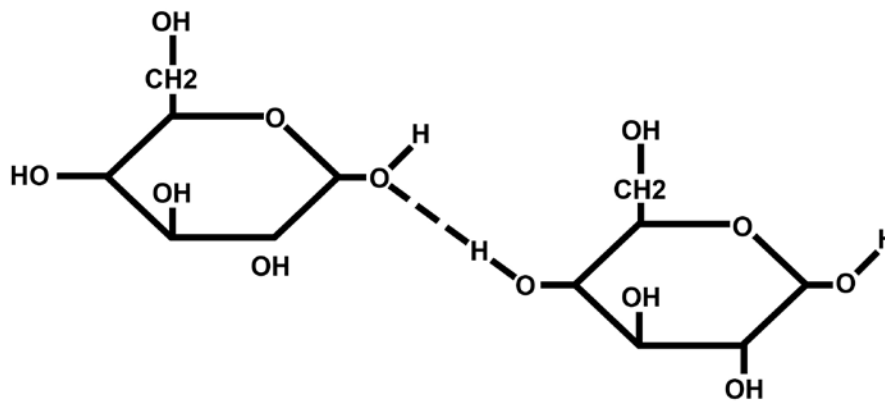

Figure 5: Cellulose bond

Anything that can increase the number of hydrogen bonds engaged at a crossing point will increase the strength of the linkage and, thus, the strength of the paper.

For simplicity, consider just two fibers and a single crossing of one over the other. If the cell wall of these fibers is very rigid, as with a glass tube for example, the area of contact at the crossing point will be small. On the other hand, if the fiber walls are very flexible, as with a bicycle inner tube, the contact area at the crossing point will be much larger. It is important to recognize that as fibers become more flexible and collapse to ribbon-like structures, the contact area increases dramatically – as does the potential number of hydrogen bonds that can be formed. The thickness of the cell wall has a dominant influence on the “collapsibility” of the fiber. For this reason, the type of wood used largely determines the potential for achieving critical paper properties. However, for any given fiber source and pulping process, it is the process of refining which essentially determines the extent to which the fibers collapse.

The degree of fiber collapse and the resulting increase in contact area are important in determining how many bonds can potentially be formed. It is also necessary that the surfaces in contact have a relatively large number of exposed bonding sites. This can be accomplished by ensuring that all the surface lignin has been removed together with the primary cell wall, and that many of the fibrils near the exterior of the S<sub>2</sub> layer are “teased” out so as to create the effect of a frayed rope. The removal of lignin and primary wall material is largely accomplished in the pulping process. The “teasing out” of fibrils, referred to as fibrillation, is accomplished in refining.

The principal objectives of stock preparation refining are thus: 1) to increase the flexibility of the cell wall to promote increased contact area, and 2) to fibrillate the external surface of the fiber to further promote the formation of hydrogen bonds and increase the total surface area available for bonding.

Now that we have examined what happens at a single fiber crossing point, we can consider what the aggregate effects are on the structure of the paper sheet.

The function of the paper machine is to convert a suspension of fiber and water into a relatively moisture-free web with specific characteristics. If you visualize a layered structure of fibers piled one on top of the other, the thickness of the resulting paper may be equivalent to anywhere from five individual fiber thicknesses up to several tens of fiber thicknesses. If the fibers act like rigid cylinders, the paper sheet will be very thick and full of void spaces (i.e. it will be bulky); whereas if all the fibers collapse to ribbons, the sheet will be much thinner and denser. Indeed, the most evident result of refining is an increase in the density of the paper that is formed. Along with this increase in density comes a reduction in air permeability (or porosity), an increase in tensile strength, and often a reduction in tear strength. Whether or not a reduction in tear strength occurs, refining almost always increases the fracture toughness of the sheet. It is easy to imagine that surface smoothness will be better when ribbons are used in place of rigid cylinders, so long as the ribbons lie flat in the plane of the sheet. Figure 6 shows a typical cross section of paper, illustrating quite clearly how fiber collapse might affect several paper properties.

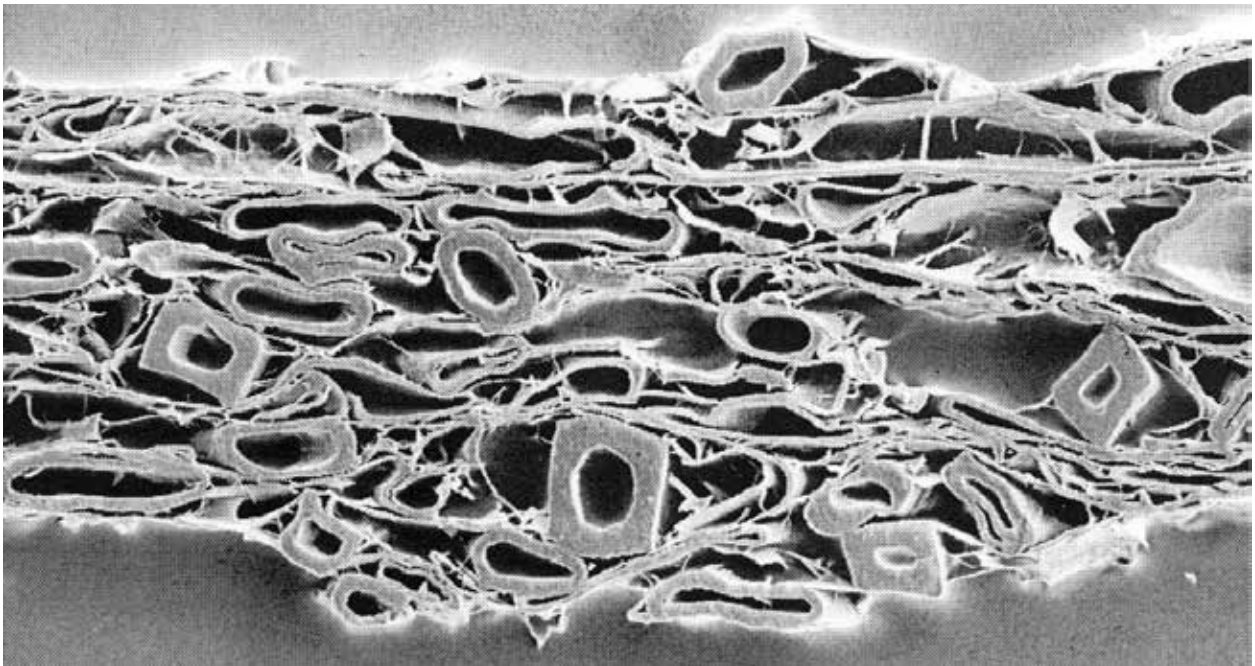

**Figure 6: Cross-section of paper**

Another effect of increasing bonding and paper density is to make the resultant sheet less opaque (i.e. more transparent). For printing papers, this is an undesirable side effect because sheet opacity is important in preventing the printing on one side of the paper from showing through on the other side.

It is important to remember that there are other steps in the forming process that substantially affect paper properties. After the sheet is formed on the machine, water is removed in the press section where the nature and extent of press loading can have considerable effects on paper properties. Pressing increases the density of the wet mat and of the finished paper as well. In the drying section of the machine, conditions will again affect final sheet properties. Hydrogen bonds form when intervening water is removed, after which a significant amount of shrinkage takes place both in the individual fibers and in the paper sheet. Fibers shrink mostly in the cross-wise direction rather than along their length. However, the cross-wise shrinking of one fiber can cause a length-wise compression of a fiber that is bonded to it in a perpendicular orientation. The resulting internal stresses can dramatically affect paper properties (e.g. dimensional stability, curl). The extent to which the sheet is restrained during drying can play a large role in determining paper performance.

Clearly, while refining is a very important step in engineering the structure of paper, is only one of several critical process steps. It is impossible to optimize any one of the critical steps without due consideration of the others.

So far, we have discussed the refining process and how it affects paper structure in a mostly qualitative way. In later sections, we will try to quantify the process and learn how to use refiners and refiner fillings to assist the paper maker in achieving economic and product quality benefits. We will first review some common measurements of pulp and paper quality, and then look at specific factors that affect the performance of refining equipment.

## 5. Pulp Quality Measurements

A number of analytical tests can be performed on pulp samples. Some measure chemical characteristics while others measure physical attributes. Most provide information that is useful in predicting the properties and performance of the end product made from that pulp. The most common tests are described below. Many of the following descriptions will relate to TAPPI (Technical Association of the Pulp and Paper Industry) standard test procedures. It is important to recognize, however, that there are many European standards which are equally applicable and, in some cases, more widely practiced.

### **Moisture Content**

For pulp that has been formed into sheets, moisture content is determined by weighing a representative sample collected from several locations within a bale and then oven drying to remove all water. The difference between the original sample weight and the oven dried sample weight represents the amount of moisture present in the original sample. A percentage is determined by dividing the amount of moisture by the original sample weight. For dry pulp sheets, moisture content is usually between 5-15%. For wet lap pulp, moisture content is typically 50%-60%.

### **Consistency**

This test measures the dry solids concentration of a suspension of fiber in water. A representative sample of pulp is collected, it is filtered to remove free liquid, and then oven dried to remove all remaining water. In stock preparation refining systems, consistency is normally between 2% and 6%. This permits relatively easy pumping of the slurry using conventional centrifugal pumps.

### **Kappa Number**

The result of a quantitative chemical analysis, the Kappa number of a pulp indicates the extent to which lignin has been removed in the chemical pulping process. A high Kappa number, indicating a greater amount of retained lignin, is common for unbleached pulps used in the production of linerboard or bag paper. If the pulp is to be bleached, the Kappa number of the pulp before bleaching predicts the bleachability of the pulp. Low Kappa pulps are easier to bleach. High Kappa pulps usually require more energy in refining, but often produce stronger paper or board (particularly with regard to tear strength).

### **Viscosity**

There are a number of standard tests in which a sample of pulp fibers is dissolved in a suitable solvent, and the viscosity of the resulting solution is measured. This viscosity indicates the degree of polymerization of the cellulose and is a measure of the degradation of the cellulose in the pulping and bleaching process. The lower the molecular weight (or degree of polymerization), the more degraded is the cellulose and, in general, the lower the physical strengths of the paper or board produced.

## **Fiber Length**

The average fiber length of a pulp has a direct bearing on many of the important physical characteristics of the paper produced. In particular, tearing resistance is very closely related to average fiber length: the longer the fiber, the greater the tear strength of the sheet produced. Screening classifiers (e.g. Bauer McNett) have been used in the past to determine the weight percentage of fibers collected on various screen sizes, but these have largely been replaced by computer automated optical devices. The most commonly used of these optical instruments are the Kajaani FS-200 and the Optest FQA. The data output of these devices can provide information such as the average length and length distribution curve for the fibers in that pulp.

## **Fines Content**

An additional measure of pulp particle size is the percentage of fines. This consists of particles measuring less than 0.2 mm in length as measured by an optical analyzer, or the weight percentage of the P200 fraction obtained from a Bauer McNett classifier. Fines can have a significant impact on processing, particularly with regard to filtering or drainage operations. Fines content of a kraft pulp may be in the range of 5– 15%. For a groundwood mechanical pulp, the fines content may exceed 40%.

## **Coarseness**

This is a measure of the average weight of fiber per unit length, often reported in units of mg/m. It is most conveniently measured using an optical analyzer. For fibers of a given average length, it is a measure of the cross sectional area of the fiber. For a given average diameter, it is measure of wall thickness. Coarse fibers are considered to be less conformable than fine fibers and do not bond as readily. Coarser fibers also result in fewer fibers per mass of pulp, which has a significant impact on sheet formation and light scattering potential.

## **Zero-Span Tensile**

This test is a measure of the intrinsic strength of individual fibers. For normal tensile strength tests (described in the next section), the jaws of the tensile machine gripping a paper sample are spaced about 7" apart. As the sample is pulled apart, many fibers pull out of the sheet by breaking fiber-to-fiber bonds. The resultant breaking load is a measure of both fiber strength and bond strength. For the Z-Span test, the gripping jaws are moved together until they are touching so that, in principle, all fibers in the tensile zone are gripped by the jaws. The fibers are then stressed to the breaking point and a measure of fiber strength is obtained.

## **Freeness**

Freeness is a measure of the drainage resistance of a pulp slurry. In the Canadian Standard Freeness (CSF) test, one liter of dilute slurry (0.3% consistency) is drained through a standard screen which captures the fibers to form a mat. The amount of water overflowing a weir and collected from a side orifice is then a measure of how fast the water drains through the mat. CSF values may be as high as 750 ml for an unrefined, unbleached softwood kraft, and as low as 30-40 ml for a fine groundwood mechanical pulp. Stock prep refining of kraft pulp will typically reduce freeness to between 600 and 250 ml depending on the starting freeness and the paper grade being produced. Freeness is a good general predictor of sheet density and, as such, is routinely used to predict strength, opacity and other physical properties of paper. Freeness is the most widely used control test in the stock preparation area of the paper mill, at least in North America. Other standard measures of pulp drainage include Schopper-Riegler (SRo), Williams slowness, and TAPPI drainage time. All of these measures can be roughly converted to equivalent CSF values.

## **Beating Response**

There are a number of standardized bench top beating devices that can be used to refine small pulp samples. The Valley Beater and the PFI Mill are two such commonly used devices. The nature of the fiber treatment in these devices is very different compared to each other and to industrial refining, and it is not possible to directly compare the results of one type of test to results of another. As beating takes place, samples are withdrawn from the test device to generate a refiner curve. In the case of the Valley Beater, samples are typically collected at 5 or 10 minute intervals over a period of 20 to 40 minutes depending on the ease of refining for a given pulp. Pulp samples taken during the beating cycle are typically tested for freeness, fiber length, fines content, and handsheet properties.

## **Handsheet Testing**

To test for sheet properties, pulp is diluted and formed into handsheets using a sheet mold and a very specific forming procedure. The wet sheets from the handsheet mold are carefully removed and pressed under standard conditions. Pressing is performed on several sheets at a time, with thin highly polished steel plates between them. The pressed sheets adhere to the steel plates which are placed on separator rings and stored in a temperature and humidity controlled room. After a specified period of drying and conditioning, the handsheets are peeled from the polished plates and set aside for physical testing. One very important factor to remember when using handsheet test results to predict machine made paper is that handsheets are fully restrained by the polished plates during the drying process. In other words, they are able to shrink in the thickness direction but cannot shrink in the X-Y plane. Machine-made paper, on the other hand, shrinks considerably in both the machine and cross directions. Consequently, sheet properties and the trends observed from beating can be very different for differing conditions of restraint during drying.

Physical and optical tests – such as tensile strength (or breaking length), tear strength, burst strength, caliper and light scattering - are performed on pieces of the handsheets cut to specification. The results of these tests are typically plotted against beating time, freeness, and/or density in order to demonstrate the beating response of the pulp being tested. Tests performed on handsheets are similar to those performed on samples of machine made paper, as described in more detail in the following section.



## 6. Paper Quality Measurements

There are a variety of tests that can be performed on paper samples. Some measure strength or toughness, others measure surface properties such as smoothness or coefficient of friction, and still others measure optical properties such as opacity or brightness.

Nearly all paper properties are a function of the density of the paper which is, in turn, largely a function of refining. In evaluating processing alternatives, it is therefore generally appropriate to examine how refining affects the sheet properties of interest at a given density. More importantly, density can have a direct economic impact since many paper and board grades are sold not by weight but by area, subject to a set of test criteria. If a producer can meet sheet specifications at a lower density (i.e. at higher bulk), there is a significant profit incentive to do so.

It is important to recognize that machine made paper will exhibit significantly different properties in the direction of travel of the web (machine direction or MD) compared with the perpendicular direction (cross-machine direction or CD). As mentioned earlier, tests performed on standard Tappi handsheets are not dependent on direction.

### **Density**

Density of paper is determined by measuring the weight and thickness (or caliper) of a sheet of paper of known area. Basis weight and caliper are usually measured using several sheets of paper in order to reduce local variations. The inverse of density is a measure of specific volume, most commonly referred to as sheet bulk.

### **Tensile Strength**

Tensile strength is measured by clamping a strip of paper between two jaws of a tensile testing machine and recording the resulting load as the moving jaw stretches the paper to its breaking point. The maximum total force applied is called the breaking load. The elongation (or strain) of the strip is also measured, and the machine usually provides an output plot of load versus elongation as well. The area under the load-elongation curve represents the tensile energy absorption (TEA), and the slope of the curve is called the elastic modulus.

### **Tear Strength**

Measurement of the out-of-plane tearing strength (or tearing resistance) is done using a pendulum type device that measures the energy absorbed in tearing a paper sample. A starting slit is cut into the sample to initiate the tear, and the load is applied to simulate a piece of paper being torn by grabbing it with two hands and ripping it down the middle. Tear strength is a function of fiber length, fiber strength, and the degree of bonding in the sheet.

### **Bursting Strength**

This test is performed by clamping a paper sample between two steel rings over a rubber diaphragm. The diaphragm is then inflated, and the inflating pressure is measured at the moment that the diaphragm bursts through the sample. Burst strength is an indicator of sheet bonding and often trends with tensile strength.

### **Compressive Strength**

There are several methods available to measure the edgewise compressive strength of a paper or paperboard sample. The Ring Crush Test is a traditional method in which a ½" x 6" strip of paper is rolled end-to-end to form a very short cylinder about 2" in diameter. The cylinder is then compressed axially between two plates and the maximum load is measured. In recent years, a short span compression test (STFI) has become more widely used. Other similar tests have been developed for corrugated board samples. Compressive strength increases with refining in a nearly linear relationship to density.

### **Internal Bond or Z-Direction Strength**

There are several test methods, the most common of which is the Scott Bond test which measures the energy or force required to separate a paper sample in its thickness direction. This is a very important property for paper or board grades that are printed on high-speed offset printing presses, where high tack inks act to separate the paper into two layers at the exit of the printing nip.

### **Stiffness**

As implied, the stiffness test measures the resistance to bending of a sample of paper. The Gurley type tester is the most common. It can be used for a variety of paper and paperboard grades by adjusting the length and width of the sample to keep the measurement within a specified range. Stiffness can be a very important characteristic of paper and is affected by refining in a complex way. It is increased as the amount of bonding increases, but decreased by the reduction in sheet caliper. Therefore, increasing the amount of bonding at a given sheet density always improves stiffness.

### **Porosity**

Sheet porosity or air permeability is determined by measuring the air flow through a known area of paper. It can be reported in two ways: 1) as the time required for a known volume of air to pass through a sample of paper, in units of sec/100 cc (Gurley porosity); or 2) as the volume of air flow per minute, reported in ml/min (Sheffield or Bendtsen). Refining always acts to close up a sheet and make it less porous. Porosity is often used as an indicator of the potential absorbency of the paper, particularly for coated grades.

### **Smoothness**

Smoothness (or, conversely, roughness) is often measured indirectly using a Sheffield, Bendtsen or Parker Print Surf (PPS) test. These tests measure the extent to which air flows between the land area of a smooth ring and the surface of a paper sample on which the ring rests. Both the air pressure and the contact pressure of the ring are carefully controlled. More sophisticated methods are available for measuring the microscopic topography of a paper sample, but none are in common use yet.

### **Folding Endurance**

This test measures the number of double folds that a paper sample will endure while subjected to a fixed load in tension. The most common test device is the MIT tester. The effect of refining on MIT fold is not clearly predictable. Folding endurance is very dependant on fiber length and coarseness, where longer and less coarse is better.

**Brightness**

The brightness test is a measure of the reflectance of light by paper. It is indicative of the apparent whiteness of a paper sample. The brightness of pulp can also be determined by preparing pulp pads or hand-sheets according to standard methods.

**Opacity**

Opacity is a measure of the relative reflectance of light by paper on a pure black background compared with the reflectance when backed by several sheets of the sample paper (or a calibrated “white” backing). It is indicative of the usually undesirable tendency for printing on one side of the paper to show through to the other side. Opacity always decreases with refining due to the fact that the bonded area between fibers is nearly transparent. Any increase in the bonded area will increase the transparency and reduce the opacity.

**Scattering Coefficient**

Light scattering coefficient is an alternative form of presentation of the opacity test above, and it is often used as an indirect measure of the relative bonded area (RBA) in a paper sample.

**Ash Content**

This test measures the non-combustible portion of a pulp or paper sample which is primarily made up of filler or coating materials. Virgin pulps also have measurable ash content as a result of minerals absorbed into the wood of the source trees. In this test, a sample of known weight is placed in an oven at a temperature of 525oC (or 900oC depending on the nature of the fillers present) and fully combusted. The weight of the residual ash after combustion is reported as the ash content.

## 7. Theory of Refining

### i) Qualitative Analysis

In this section, the details of stock preparation refining process will be examined more closely. It will be shown that fiber and pulp properties can be manipulated by altering the refiner plate configuration and the operating conditions of a refiner in order to achieve an optimal combination of paper properties.

Pulp refining is a process in which fiber flocs collect on refiner bar edges and are subsequently deformed by compressive and shear forces such that the cell wall of at least some of the fibers is permanently modified.



The nature of the cell wall modification is dependent on the magnitude of the compressive stresses (or strains) that occur during the deformation of the fiber flocs. The extent of the cell wall modification depends on how frequently fiber flocs are collected and subsequently deformed for a given mass of fiber. In pulp refining, we are interested in both the magnitude and the frequency of these deformations.

Within each fiber floc, the average cell wall deformation of individual fibers is directly related to the deformation of the floc itself: e.g. if the floc is only slightly deformed, then the average fiber cell wall deformation will also be slight. On the other hand, if the floc is greatly deformed, then the stresses and subsequent deformation of individual cell walls will be much greater. If the deformation of the fiber floc is so extreme as to cut it into two, a portion of the fibers within the floc are also likely to be cut.

Recognizing that the deformation of the cell wall of an individual fiber during refining can only be accomplished by deforming the fiber floc in which it lies is a very important concept. First, it makes it quite obvious that the nature of deformations is highly varied. Even if it were possible to precisely control the degree of deformation of the floc, the randomly distributed fibers within the floc would be subjected to a wide range of deformations. Therefore, it is only possible to speak of average degrees of deformation and average subsequent effects on fibers. Second, it underscores the importance fiber flocs. How many and how large are the flocs that support the refining load at any instant? What effect does a change in the refiner filling design have on the size and number of fiber flocs?

In the earlier section on paper structure, the two-fold objective of stock preparation refining was described as follows:

1. Increase the flexibility of the cell wall in order to promote increased contact area, and
2. Fibrillate the external surface to further promote the formation of hydrogen bonds as well as increase the total surface area of fiber available for bonding.

The more refining that is done, the greater the increase in both fiber flexibility and surface fibrillation. Yet for a given amount of refining, there is no direct evidence linking the nature of the cell wall deformation with the resulting fiber characteristics. This would require a mechanism for precisely deforming a large number of individual fibers and then applying some sort of quantitative inspection criteria on those fibers after deformation. Nonetheless, there is some indirect evidence from measured pulp and paper properties which suggests that high magnitudes of cell wall deformation tend to cause surface fibrillation and internal swelling and, in the extreme, fiber cutting. Lower magnitudes of cell wall deformation tend to promote surface fibrillation without much cell wall swelling, along with a greatly reduced likelihood of fiber cutting. Recognizing the probabilistic nature of the refining process, it is quite certain that all of these effects take place to some degree under any given refining condition. However, it is possible to control the emphasis of one effect relative to the others by controlling the intensity of refining.

In the following section, the idea of refining intensity and its relationship to cell wall deformation will be discussed. Quantitative methods for calculating intensity will be described, and the practical application of these analytical methods to papermaking problems will be reviewed. Before discussing the effects of refining intensity, it is worthwhile looking at the general behavior of paper properties as the amount of refining is increased. Figures 7a-7c illustrate typical refining trends for mill refined softwood and hardwood kraft pulps.

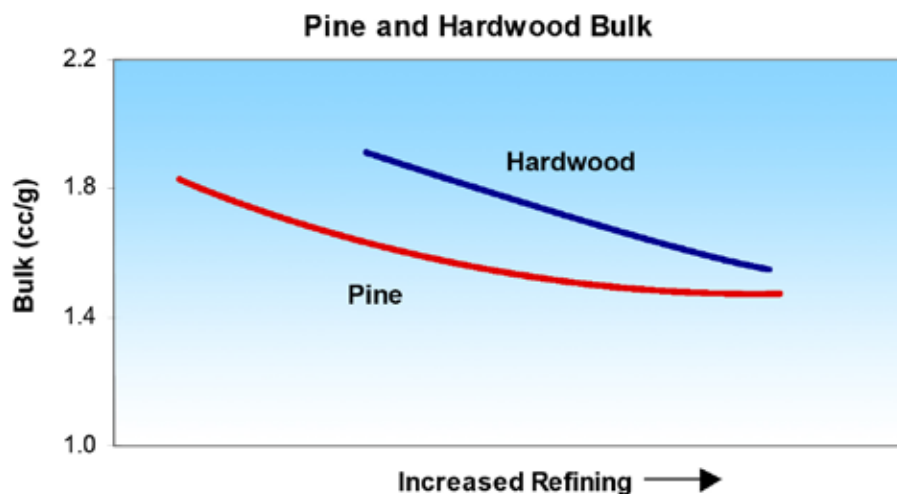

Figure 7A

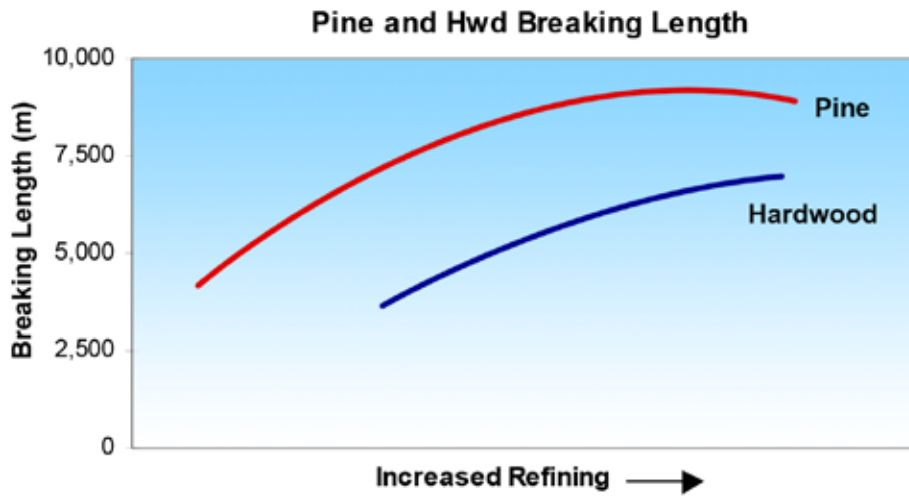

Figure 7B

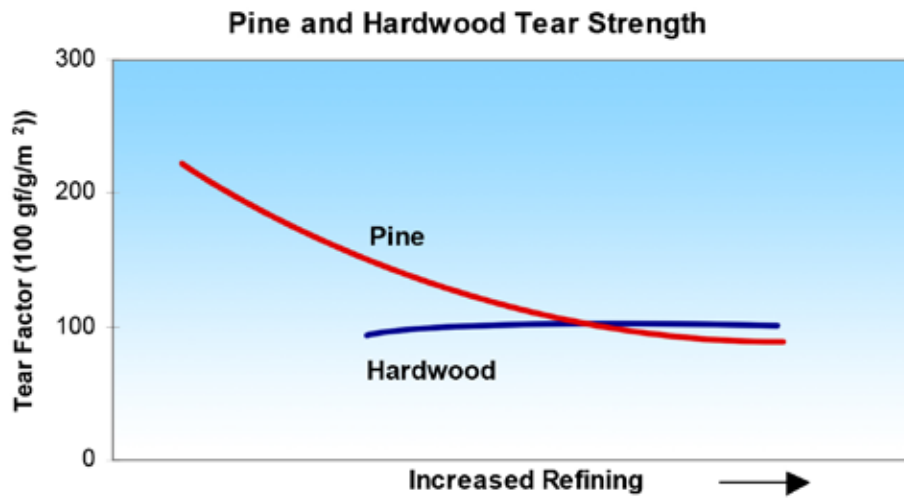

Figure 7B

## 7. Theory of Refining

### ii) Quantitative Analysis

#### Specific Edge Load Theory

At the microscopic level of fibers and fiber flocs, refining effects are dependent on the magnitude and frequency of deformations. In the macroscopic world of commercial papermaking, we cannot directly control these factors. However, we can control them indirectly by making two broad assumptions.

We can first assume that the greater the number of bar edges available in the refining zone, the greater will be the number of fibers able to absorb a given refining load because fiber flocs are collected on bar edges. The average number of crossing points where flocs can be caught between opposing edges of the rotor and stator plates can be calculated based on the inner and outer diameter of the plates, bar and groove widths, and the average radial angle of the rotor and stator bars. While the term 'bar edge length' is generally used to describe this factor, it is mathematically proportional to the average number of crossing points.

Second, we can assume that the torque applied by a refiner motor is directly proportional to the normal force acting to push a refiner rotor against a stator. This means that, with a fixed motor speed, the motor power is proportional to the normal force.

With these two assumptions, it is possible to conclude that the average magnitude of fiber deformation is directly related to the applied power divided by the product of rotating speed and edge length. This is the basis of the Specific Edge Load Theory which was first introduced back in the 1960's. The calculated variable is referred to as 'refining intensity' or 'specific edge load' (SEL), and is typically expressed in units of watt-seconds per meter (Ws/m).

In order to calculate the refining intensity, it is necessary to first determine the true load applied to the fibers. In a commercial refiner, there is significant power consumption resulting from hydraulic losses. The bars and grooves of the refiner filling accelerate and decelerate the fluid as it passes through the refiner, causing a heating of the fluid but no net refining effect on the fiber in the process. This is called the 'no-load power' and it must be subtracted from the total motor load in order to accurately define the net power actually applied to the fibers. A complete discussion of no-load power and how it is determined is included in appendix A.

Given these relationships, the intensity (I) of refining may be calculated according to the following equation:

$$I = (\text{Applied Motor Power} - \text{No-Load}) / [\text{RPM} \times \text{Bar Edge Length} \times (\text{min}/60\text{s})]$$

To define the refining process, it is not enough to know the magnitude or intensity of deformations. It is also necessary to know the frequency or, more accurately, the average number of deformations per unit mass. Computing the average number of deformations requires the assumptions that the deformation at any crossing point occurs over a finite time interval, and that the number of deformations per unit time is directly proportional to the rotating speed. Thus, the number of deformations per unit mass (N) is calculated according to the following equation:

$$N = (\text{RPM} \times \text{Bar Edge Length}) / \text{Tons per Day}$$

Since the amount of refining (P) is by definition equal to the product of the magnitude and the number of deformations, it can be calculated according to the following equation:

$$\begin{aligned} P &= I \times N \\ &= \{(\text{Net Power})/(\text{RPM} \times \text{Bar Edge Length})\} \times \{(\text{RPM} \times \text{Bar Edge Length})/ t/d\} \\ &= \text{Net Power}/ t/d = \text{net hpd}/t \end{aligned}$$

The traditional application of refining theory usually refers to the specification of two parameters: Specific Energy (equal to P above) and Intensity (equal to I above). There is seldom any specific reference to N. However, a useful insight is gained by knowing that applied power determines the magnitude of deformations while throughput determines the number of deformations.

### **C-Factor Analysis**

In recent years, the introduction and application of the C-Factor analysis by R.J. Kerekes et al. has lent substantial credibility to the notion of I and N. The C-Factor analysis takes the refining theory a step further by incorporating values for average fiber length and fiber coarseness in order to calculate I and N on a 'per fiber' basis.

C-Factor analysis also takes into account certain factors relating to bar and groove geometry which provide for a more accurate description of refining intensity.

It is appropriate to use both Specific Edge Load and C-Factor methods when analyzing a refiner filling application. It is important to recognize that SEL does not take into account fiber characteristics but does provide a benchmark value for which there exists a great deal of historical information.

The actual equation for the C-Factor calculation is too complex to include here. In fact, it is somewhat tedious to perform the calculation in the absence of a computer program. Virtually all C-Factor analyses are performed using a spreadsheet program that requires input information regarding refiner size, speed, no-load power and motor load. It also requires input on refiner filling configuration (including bar and groove widths, depths and radial angles), as well as input regarding pulp consistency, throughput, fiber length and coarseness. The output of the spreadsheet program includes a value called the C-Factor which of itself is not physically meaningful, and the two values I and N on a per fiber basis.



## 8. Refiner Plate Selection:

### i) The Correct Amount of Refining (Specific Energy Input)

The net specific energy consumption of a refiner or refining system determines the amount of refining that is applied to a pulp. As indicated in the preceding section, it is calculated by dividing the net applied power by the throughput according to the following equation:

$$\text{Net Specific Energy} = (\text{Total Applied Power} - \text{No Load}) / \text{t/d}$$

Common North American units are horsepower per short ton per day, or hpd/t. The common metric units are kWh/metric ton.

The throughput in t/d or t/h is based on moisture free fiber (also referred to as oven dry or bone dry basis), and can be calculated if both the flow rate (in gallons per minute or liters per minute) and the consistency are known:

$$\begin{aligned}\text{short t/d} &= \text{Flow (gpm)} \times 6 \times \% \text{ Consistency} \\ \text{metric t/h} &= \text{Flow (lpm)} \times 0.06 \times \% \text{ Consistency}\end{aligned}$$

#### Example calculations:

- a) With a flow rate of 500 gpm and a consistency of 4.5%, the throughput is:  
 $t/d = 500 \times 6.0 \times 0.045 = 135 \text{ st/d}$
- b) With a flow rate of 1200 lpm and a consistency of 5.3%:  
 $t/h = 1200 \times 0.06 \times 0.053 = 3.8 \text{ mt/h}$
- c) If the motor load is 575 hp and the no-load power is 115 hp, then the net applied power is:  
 $575 - 115 = 460 \text{ hp}$   
and the specific energy input is:  
 $460 \text{ hp} / 135 \text{ t/d} = 3.4 \text{ hpd/t}$

To convert from hp to kW, multiply hp by a factor of 0.746. The equivalent specific energy calculation for the flow rate of 1200 lpm would then be:

$$\begin{aligned}(575 \text{ hp} \times 0.746) - (115 \text{ hp} \times 0.746) &= 342 \text{ net kW} \\ 342 \text{ kW} / (1200 * 0.06 * 0.053) &= 90 \text{ kWh/t}\end{aligned}$$

According to these equations, if the applied motor load is increased or if the throughput is decreased, then the net specific energy will increase.

The specific energy required for a given installation is usually determined based on historical experience at a given mill. Even for the same or similar grades, and the same fiber source and pulping process, two paper mills may apply significantly different specific energy levels in the stock preparation refining system. Table 4 shows some typical energy ranges for different paper and paperboard grades.

**TABLE 4**

Grade		Net hpd/t
Fine Paper	HWD Kraft	2-5
	SWD Kraft	3-7
	Tickler	1-1.5
Linerboard	Base	5-7
	Top	10-12
News	SWD Kraft	2-5
	TMP/GWD	1-5
GWD Printing Paper	SWD Kraft	3-7
	TMP/GWD	3-6

An estimate of the specific energy requirement can be made for a given type of pulp if the unrefined pulp freeness and the target freeness level are known. By subtracting the target freeness from the unrefined freeness, the total amount of freeness change is calculated. Values in Table 5 can then be used to predict approximately how much energy should be required to achieve the desired freeness drop.

**TABLE 5**

Furnish	Freeness Drop / Net hpd/t
Bleached SWD Kraft	20-40 ml
Bleached HWD Kraft	60-100 ml
GWD	3-7 ml
OCC	40-70 ml
Mixed Office Waste	50-70 ml
News	20-35 ml

Note that this represents a rough guideline only. It is often the case that specific energy requirements are best determined based on paper quality checks during mill processing. It is therefore advisable that the available power for refining be around 25% greater than the expected nominal level.

## 8. Refiner Plate Selection:

### ii) The Correct Intensity of Refining (Specific Edge Load)

Determining “the best” refining intensity for a particular refining application can be considerably more difficult than specifying the required specific energy input. Even with a substantial background of mill operating data, designing a refining system to operate at optimal intensity involves several economic trade-offs. Hence, it requires a clear understanding of the economic impact of paper quality improvements.

If a pulp is only lightly refined, the refining intensity is usually not so important because there is not enough fiber modification taking place to make the difference discernable. An exception to this is the refining of unbleached kraft for sack paper applications for which the initial increase in tear with refining can only be assured if the intensity is sufficiently low (i.e. 1.5-2.0 Ws/m).

The benefits of low intensity refining for hardwood pulps and for mechanical pulp post-refining are quite widely acknowledged by papermakers. In the past, the lower limit of intensity had been established at 0.6-0.8 Ws/m due to the limitations of plate manufacturing technology. However, recent developments in this area have enabled intensities of 0.1-0.5 Ws/m to be achieved while maintaining efficiency and hydraulic capacity.

Low refining intensity has long been considered unnecessary for softwood pulps and deemed too costly in terms of potential increases in specific energy requirements. This view is changing as many mills are seeking gains in tear strength and toughness that lower refining intensity can provide. Many mill refiners currently operate in the range of 2.0 – 4.0 Ws/m. Any easily achieved reduction in intensity will almost always be beneficial to quality.

For hardwood pulps, low refining intensity results in greater bulk and opacity at a given level of most strength properties. There is no substantial evidence to demonstrate that refining intensity can be too low in the case of hardwood pulps. Many mill refiners operate in the range of 0.6-1.0 Ws/m, and nearly all applications could benefit from any reduction achieved by changing plate patterns. Another key benefit of low intensity refining for hardwood is the reduction in energy required to achieve a given pulp quality or drainage level. Figure 8 shows a compilation of pilot plant and mill data illustrating the impact of intensity on freeness drop for various bleached hardwood pulps.

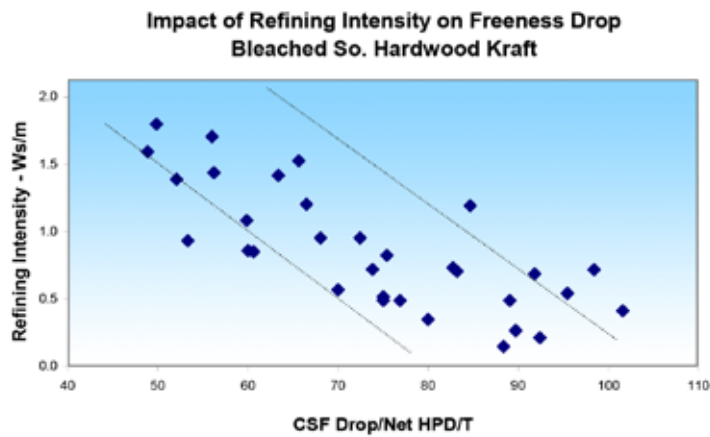

**Figure 8:** Refining intensity vs freeness drop

The data points clearly show a trend of increased freeness drop per net hpd/t applied as the refining intensity is reduced from 2.0 to 0.2 Ws/m. In other words, less energy is needed to achieve a given freeness. This can be taken as an operating cost reduction, or as an increase in power available for quality enhancement or to accommodate a higher throughput.

For mechanical pulp post-refining, low refining intensity will yield higher freeness, increased fiber length and improved tear strength at a given debris level and energy input. At an equivalent freeness (with higher specific energy input), reduced debris levels can be obtained.

Table 6 lists recommended ranges of refining intensity for various types of fiber. For most applications, refining intensity should be as low as is practically achievable in order to maximize pulp quality potential.

**TABLE 6**

Fiber Type	Refining Intensity (Ws/m)
SWD Kraft	1.0-2.5
HWD Kraft	0.1-0.5
Recycle	0.2-0.8
TMP/GWD	0.2-0.5

In certain softwood refining applications, reducing the total power consumption or increasing the power available for refining can be more beneficial than achieving the lowest possible intensity level. In these instances, it is often possible to reduce the active diameter of the refiner by using reduced periphery plates. The reduced active diameter will have a lower no load power demand.

The relationship between plate diameter and no load is as follows:

$$\text{No load power} = k * \text{diameter}^{4.3} * \text{rpm}^3$$

Table 7 demonstrates the potential energy savings that would result from a reduction in the active diameter of refiner plates operating at typical speeds.

**TABLE 7**

Active Plate Diameter (in)	Reduced Active Plate Diameter (in)	Estimated Power Savings (Hp)	Annualized Savings at \$0.05/kWh
46	43	83	\$27,120
46	40	150	\$49,000
42	39	90	\$29,400
38	35	65	\$21,240
34	31	45	\$14,700
30	27	45	\$14,700
26	24	33	\$10,800

Depending on the specific circumstances, a mill may choose to take the economic benefit of the no load power savings, or they may use the additional available energy to achieve quality benefits.

Whether full diameter or reduced periphery plates are used, it is nearly always beneficial to use the narrowest practical bar width and groove width in any refiner. The practical limits of bar and groove width depend on the specifics of the application.

**The following guidelines apply:**

**Bar Width**

In the absence of potential metal contamination and no-load power concerns, the width of bars would be only as great as required to rigidly hold the flocs of pulp that are being deformed. In real situations, the bar width is dictated mostly by the metal contamination potential of the application. Metal contamination introduces bending loads on the bars that far exceed the normal refining load. As a result, the minimum practical bar width is usually in excess of 0.050". Experience has shown that in a refiner where baling wire contamination is likely, the minimum bar width should be in the order of 0.075".

**Groove Width**

The minimum practical groove width is usually determined by the tendency for plugging of the groove, either by fiber or by a common contaminant. For post-refining of groundwood in a contaminant free system, a groove width of 0.050" would be possible. For hardwood pulps the groove width should be at least 0.075". For softwood pulps the groove width should be at least 0.090" or 0.125", depending on the average fiber length of the species being refined. Another factor to consider is that no-load power varies directly with the hydraulic section or open area of the cross section of the pattern. A plate with 1/8" grooves and 1/4" bars will have a higher no-load power than a plate with 1/4" grooves and 1/8" bars.

Minimum bar and groove widths create the lower limit of refining intensity for any given refiner size operating at a fixed speed. If there is a strong quality incentive to reduce intensity further, it can only be done by adding additional equipment.

## 9. Flow Considerations in a Stock Preparation Refiner

All stock preparation refiners are hydraulic machines with high speed rotating elements. That means that they operate in an incompressible medium (no appreciable air or other vapor present) and are subject to the considerable influence of fluid friction and centrifugal forces. They act much like centrifugal pumps, albeit with very leaky wear plates.

As discussed previously, the capacity of a refiner may be limited by the available net power which will limit the amount of refining that can be done. It is very important to recognize that the capacity of a refiner is also limited by its ability to pass a volumetric flow. The flow capacity of a refiner is determined by its disk diameter, its operating speed, and the hydraulic section and pumping angle of the installed refiner plates. Table 8 contains the recommended flow ranges for different sizes of double disk refiners. In most instances, the high end of these ranges is very optimistic and will result in poor refining with very short useful plate life. High flows are primarily encountered with tickler refiners where the entire flow of the paper machine stock must pass through the refiner.

A complete discussion of the various flow configurations for stock prep refiners and the flow rate/pressure relationships is included in Appendix B.

**TABLE 8**  
**DOUBLE DISK REFINER CAPACITY CHART**  
Recommended Flow Ranges for Various Size Refiners

Plate Diameter (in)	Max Power (Hp)	Rotor RPM	Nominal No Load (Hp)	Flow Rates (GPM)		
				LOW	MED	HIGH
20	300	720	75	150	250	400
24	450	720	85	250	350	600
26	500	720	120	300	450	800
30	600	600	125	375	600	1100
34	800	514	135	475	750	1400
	1000	600	215	550	875	1650
38	1250	514	215	650	1075	2025
42	1500	450	220	775	1250	2400
	1750	514	330	900	1450	2800
46	2000	450	325	1025	1675	3275
52	3000	400	385	1300	2150	4300
	3000	450	550	1475	2425	4850
54	3000	400	450	1475	2425	4850

## 10. Conclusion

This training manual was designed to provide the reader with a general overview of the stock prep refining process. There are many steps in the complex process of converting wood into paper but many consider refining to be the heart of papermaking. Refining plays an important role in modifying the characteristics of fibers so that they may form a sheet of paper or paperboard with a specific set of desirable properties such as stiffness, fiber bonding and surface smoothness, to mention just a few. Proper selection of refiner plates and operation of the refiners is key to optimizing the quality of the paper being produced using available raw materials. Check out our other resources at [www.aikawagroup.com](http://www.aikawagroup.com) to learn more about refining science and help address your stock prep challenges.

### General Bibliography

1. Smook, G.A.; Handbook for Pulp & Paper Technologists; Tappi Press (1988)
2. Isenberg, I.H.; Pulpwoods of the United States and Canada (1981)
3. Paulapuro, H.; Papermaking Science and Technology Book 8: Papermaking Part 1, Stock Preparation and Wet End; Finnish Paper Engineers' Association and Tappi Press (2000)
4. Scott, W.E. and Abbott, J.C.; Properties of Paper: An Introduction, 2nd edition; Tappi Press (1995)

[www.aikawagroup.com](http://www.aikawagroup.com)

[sales@aikawagroup.com](mailto:sales@aikawagroup.com)

**Varkaus FINLAND**

Tel: +358 207 429 200  
Fax: +358 207 429 280

**Sherbrooke CANADA**

Tel: +1 819 562 4754  
Fax: +1 819 562 6064

**Incheon KOREA**

Tel: +82 32 814 2825  
Fax: +82 32 815 2825

**United States**

Tel: +1 800 223 0060  
Fax: +1 819 562 6064

**Brazil**

Tel: +55 19 3024 0700  
Fax: +55 19 3024 0300

**Jiaxing City CHINA**

Tel: +86 573 8391 3279  
Fax: +86 573 8391 3298



## Appendix A

### No-Load Power In a Stock Preparation Refiner

In all pump-through refiner applications, a certain amount of applied power is consumed by the hydraulic pumping effect and the energy loss associated with viscous shearing of the fluid. This is called the “no-load” or circulating power. This energy produces no measurable change in the properties of the pulp being refined, except in the case of very sensitive pulps and/or very low relative throughput rates.

No-load power is mostly dependent on the diameter and rotational speed of the rotor, but it can also be significantly affected by the bar and groove configuration of the refiner plates. Factors such as flow rate, stock consistency and plate gap have a relatively minor influence. Contrary to frequent supplier claims, no-load is not dependent on the weight or mass of the rotating elements. The inertial mass of the rotating elements affects only the acceleration time for the motor-refiner system at motor start, and the resulting torsional loads on the rotating system.

Since all changes in pulp properties are determined by the “effective” power applied (i.e. total motor power minus no-load power), it is important to know what is the actual no-load power for any given refiner, installed plate pattern, and relative plate wear.

No-load can be determined by careful measurement or it may be calculated in accordance with theoretical formulas. A precise measurement of no-load power requires that the rotor be firmly held so as to prevent contact with the stators on either side. Because of the radial variability in the static pressure profile acting on each side of the rotor, it is often the case that instability exists which causes the rotor to lean against one or the other of the stators. If only water is present, it will result in noisy contact and a slight increase in the measured load. The absence of a fiber mat will also result in a slight scarring of the bar surfaces of the refiner plates. If fiber is present, this instability can result in a significant increase in measured load and is usually the cause of incorrect no-load measurements. It is important to recognize that, for any given refiner with a given plate pattern, the no-load power will vary considerably from a maximum value when the plates are new to some much lower value (as much as 60-80% lower) when the plates are fully worn.

Since it is somewhat difficult to obtain an accurate measurement of refiner no load, it is often easier to rely on the calculated value. With an extensive collection of historical data, refiner and refiner filling manufacturers have developed quite reliable predictive models for this purpose.

Most formulas used for calculating no-load power are based loosely on the affinity laws used in pump design. Indeed, a refiner does behave much like a pump, albeit a very inefficient one. Every plate pattern will exhibit a characteristic curve that describes how the total head (pressure rise) varies with capacity (flow rate). The pressure rise will be at a maximum at zero flow, and will decrease as flow is increased, and actually become a pressure drop at a sufficiently high flow rate.



As with a pump impeller, pumping power (or no-load) in a refiner is proportional to the third power of rotational speed. However, unlike a homologous series in pump impellers, the no-load power for the refiner is proportional to the active plate diameter raised to the power of 4.3.

In addition to the effect of diameter and speed, the groove depth and hydraulic section ratio have a dramatic effect on no-load for a particular refiner plate configuration and wear condition. The hydraulic section ratio is the ratio of groove width to the sum of bar and groove width, accounting for any effect of tapered groove walls. Based on these relationships, a formula for the calculation of no-load power is:

$$NL = 102 \times (RPM/100)^3 \times (Da/100)^{4.3} \times (2 \times Gw / (Bw + Gw)) \times (Gd / 4)$$

where, NL = no-load (measured in horsepower)  
RPM = rotational speed of the motor (revolutions/minute)  
Da = diameter of the active surface of the refiner plate (inches)  
Gw = groove width (sixteenths of an inch)  
Bw = bar width (sixteenths of an inch)  
Gd = groove depth (sixteenths of an inch)

An example of this calculation can be found in Appendix C.

Note that most published no-load data for refiners is based on brand new cast refiner plate fillings with a typical bar and groove width of 2.0 sixteenths and an available groove depth of about 4.0 sixteenths (0.25 inches).

## Appendix B

### Flow Considerations In a Stock Preparation Refiner

All disc refiners used in stock preparation applications consist of one or more pairs of discs, one rotating and one stationary, both with working surfaces made up of bars and grooves. These discs are contained within a pressurized vessel. The process stream consists of aqueous slurry of wood pulp fibers which is usually delivered to the refiner by a centrifugal pump. The flow rate through the refiner is usually established by setting a valve located in the piping on the discharge side of the refiner. The suspended solids concentration, or stock consistency, is typically in the range of 2-6% oven dry solids by weight. For the purpose of analyzing fluid flow behavior, the process stream can be considered to be an incompressible fluid with flow properties similar to water. Pumping characteristics up to about 6% consistency will be essentially the same as for water. Friction loss in pipe flow will be slightly different depending on several factors, including consistency and type of pulp being processed.

While stock preparation refiners may in principle have many disc pairs, the vast majority are of the double disc (DD) type. A schematic cross section of a double disc refiner is shown in Figure 9. The rotating disc is free to float and is 'sandwiched' between the two non-rotating discs. Also shown in Figure 9 is the disc position numbering system that will be used throughout this discussion. Position #1 refers to the stationary disc that is closest to the drive motor.

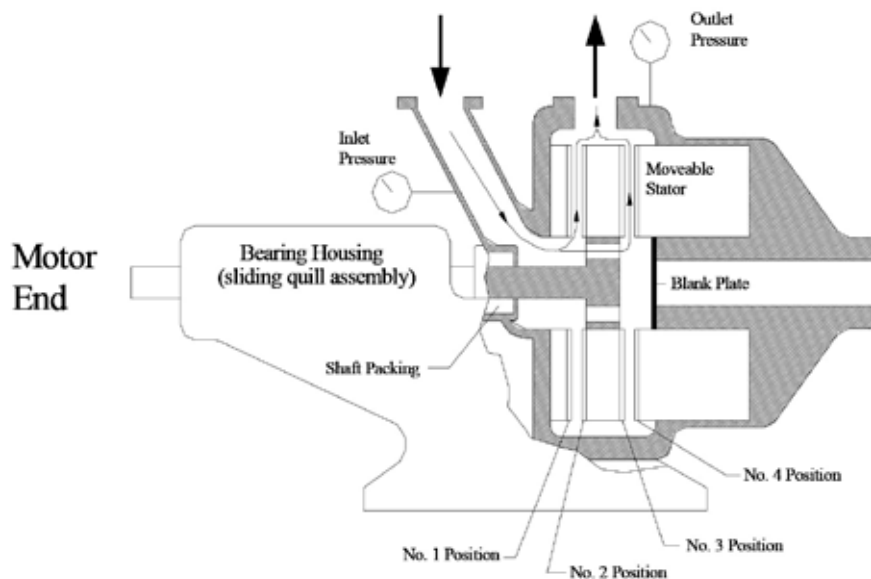

Figure 9

Double disc refiners can be operated in any one of three modes: duo-flo, twin-flo, and mono-flo mode.

## DUO-FLO or TWIN-FLO OPERATION

Most double disc stock preparation refiners operate in the duo-flo or twin-flo modes. Although arguments have been made regarding the ability to control the flow split using one alternative or the other, there is little reliable evidence to support either claim. In most circumstances, it is the pumping capacity of the refiner plates that largely determines the flow split and, more importantly, the force balance that acts on the floating rotor. In order for the refining effect to be the same for the flow streams on each side of the rotor, it is necessary for both the intensity of refining and the amount of refining to be the same. Meeting both these requirements simultaneously requires that the closing force acting on the two disc pairs is the same and that the flow rate passing between each disc pair is the same. In order for the closing force to be the same, it is essential that the rotor be free to slide. Resistance to sliding can occur in (a) the sliding coupling, (b) the sliding bearing support, or (c) the rotating shaft seal which is usually a packing box. All three areas represent critical maintenance items for a double disc refiner. In addition to these three prerequisites, equal closing force also requires that the pressure acting against each face of the rotor be the same. Since the pressure acting against opposing rotor and stator plates is dependant on flow rates and the related pressure rise between the inside diameter (ID) and the outside diameter (OD), it is important to have an understanding of the fundamental hydraulic principles involved. Proper selection of the plate pattern, process flow arrangement and control strategy depend on a clear understanding of the hydraulic forces that are at work.

For the purpose of this discussion, we will first consider the case of a single disc pair with flow passing between the plates from inside to outside, and with perfectly radial bars and grooves. The rotor plate acts like a pump impeller. Pressure rise in an impeller of given diameter is determined firstly by impeller speed, and then by flow rate. At peripheral speeds that are typical for pump-through disc refiners, pressure rise at zero flow rate would be about 6-7 bar if the stator had no grooves but was instead a smooth plate against which the rotor bars were to run. With such a smooth stator arrangement, we could generate a characteristic curve for this pump that would look something like the curve labeled “smooth stator” in Figure 10. With a real disc pair, the stator in fact has grooves of about the same hydraulic cross section as the rotor plate. These stator grooves allow fluid to leak back toward the ID. The result is that the observed pressure rise is much lower for the real disc pair, usually 1-2 bar at zero flow. Thus, in the real case, the curve looks more like that labeled “normal stator” in Figure 10. In this example, the flow rates shown are typical of a single disk pair with a 34” DD refiner. This is the characteristic curve for this particular hypothetical plate pattern. Every plate pattern operating at a particular speed has a unique characteristic curve. Most double disc refiners operate at peripheral speed of around 90 ft/sec. As the size increases, the rotational speed is reduced in order to maintain the same peripheral speed, and so the maximum pressure rise is generally found to be in the range of 1-2 bar at zero flow. For refiners operating at low speed, the maximum rise will be somewhat lower; and for refiners operating at relatively high speed, the maximum rise will be somewhat higher. Flow capacity at a given pressure rise varies more or less according to the square of the diameter. Thus, nominal flow capacity for a 42” refiner will be about 4.5 times that of a 20” refiner.

The bars and grooves of a refiner plate are typically angled with respect to a radial line such that they encourage an outward flow of the pulp (“pumping” orientation). They can also operate in such a way that they inhibit outward flow (“hold back” orientation). The effect of reversing bar angle orientation is the same as simply reversing the direction of rotation of the rotor. It is very important to realize that the primary pumping influence in a disc refiner (or in a pump for that matter) results from the centrifugal force created by rotation of the fluid. Changes in the bar angle simply affect the efficiency of the pumping effect and cannot overcome the centrifugal force. No amount of hold back angle can produce a pressure drop at zero flow rate.

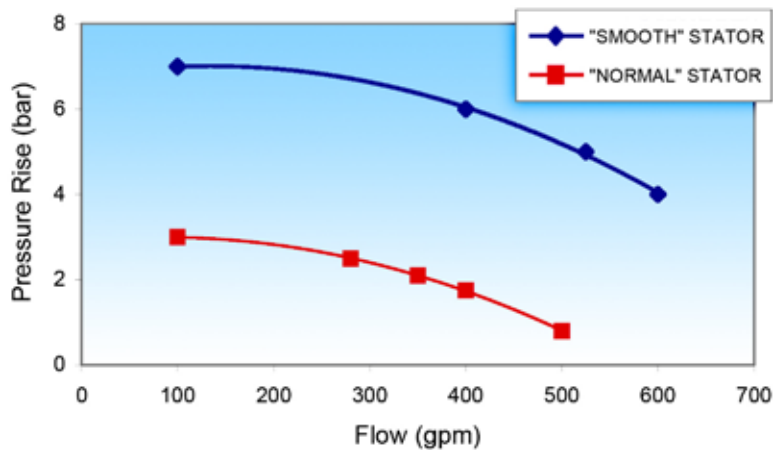

**Figure 10: 34'' DD Characteristic Curve**

In the case of refiner plates, there is one more aspect that complicates the characteristic curve: plate wear. The characteristic curve for a pump impeller is very dependent on the height of the vanes of the impeller. As the typical pump impeller wears, this height changes only modestly if at all. In the case of refiner plates, the height of the bars can change dramatically over time. If the vane height of a pump impeller were reduced by half, the capacity at a given pressure rise would be reduced by half. The same is true of the pumping capacity of the rotor plate of a disc refiner. For the disk refiner, there is the further complication that both the stator and the rotor plates can wear. Remembering that stator grooves represent the path for high-pressure fluid to leak back toward the center of the refiner, the loss of capacity of the rotor as the stator plates wear is at least partly offset by the reduction in the “leak-back” rate of the stator.

In a double disc refiner operating in duo-flo mode, it should now be apparent that the two disc pairs behave like two parallel pumps with a common suction and a common outlet header. Since the inlet and outlet pressures are identical, the flow will be essentially the same on both sides as long as the bar and groove depth is the same. And, although it is possible even with duo-flo mode to have some imbalance of forces acting on the rotor, usually the imbalance is small and the wear occurs more or less evenly between the two disc pairs. In any case, it is relatively easy to establish the characteristic pump curve for the duo-flo refiner with any given set of plates installed. By varying the flow through the refiner in increments and by recording the inlet and outlet pressure at each flow rate, the necessary data is generated to plot the characteristic curve.

It was mentioned above that the hydraulic forces acting on each side of the rotor are approximately the same in a duo-flo refiner. While this is generally true, it is nevertheless possible to have an imbalance that can measurably affect the quality of the refining result. Such an imbalance usually results from small differences in the pumping capacity of the #1 and #2 plate pair compared with the #3 and #4 plate pair. In the case of new plates, this is usually due to manufacturing irregularities in the refiner plates themselves. In the case of plates that have been in operation for some time, it is usually due to a difference in wear that has occurred between the two plate pairs. In a refiner with mirror image plates in the #1 & #4 position and in the #2 & #3 position (as is usually the case), differences in wear are almost always a result of mechanical resistance to sliding and not due to hydraulic imbalance. Hydraulic imbalance tends to be self-correcting because the deeper groove side of the rotor will have a higher flow rate. As will be seen later, higher flow rate means a flatter pressure profile which results in a reduced normal force acting on the rotor.

Measurements have been made to determine the relationship between the closing force acting on a single disc pair and the resulting refining load in a 34" refiner. These results suggest that a difference of 0.1 bar in average pressure acting against the two opposite rotor surfaces could result in a difference of 40 kW in net power consumed between the two disc pairs. With a combined net applied load of 200 kW for the two disc pairs, 80 kW may be applied to the #1 and #2 plates while 120 kW may be applied to the #3 and #4 plates. In the best circumstance, the difference in flow that has produced the 0.1 bar average pressure difference is in exactly the same proportion as the difference in resulting refining load. In that case, the specific energy applied in both disc pairs would be the same. However, the refining intensity would be 50% higher for the #3 and #4 plate pair. In fact, it may take only a slight difference in flow to produce an imbalance in load that could significantly impact both the amount and the intensity of refining.

Again, in most cases of duo-flo operation, hydraulic imbalance of the rotor is not a problem. As long as the flow through the refiner results in a pressure rise of no more than about 1.5 bar, then differences will be quite small and the impact on the refining effect will be negligible. At very low flow rates, particularly in combination with high rotational speeds and high capacity refiner plates (e.g. with relatively wide and deep grooves), the pressure rise may be significantly higher. In order to ensure proper rotor balance in these instances, it is usually recommended to operate with a recycle flow. This will allow the flow through the refiner to be kept high, even if the net forward flow to the paper machine is low. Even with a pressure rise of 2.0 bar, satisfactory operation can be achieved if the refiner is normally operated at 80% or more of full power.

## **MONO-FLO OPERATION**

In the case of mono-flo operation, the hydraulic situation in the refiner is much more complicated. It is primarily for this reason that few refineries are operated in this mode. While there is little information available comparing the quality benefits of mono-flo and duo-flo operation, there are several paper mills that believe the benefits of mono-flo are worth the added complexity of plate selection and operation.

In a mono-flo refiner, stock flow follows a series arrangement by entering the refiner through the first disc pair and exiting through the second pair. The first disc pair (#1 & #2) acts like a centrifugal pump, just as in the case of duo-flo. That first pair operates according to a characteristic curve at one-half the flow of the equivalent duo-flo refiner. The second disc pair (#3 & #4 position) is hydraulically more complicated. The centrifugal forces that create a normal pumping effect are partly offset by reverse angled bars. Still, it requires a considerable pressure to force the stock flow from the OD to the ID of the #3 & #4 pair. As a result, the pressure rise developed in passing through the #1 & #2 pair is used to drive the flow back through the #3 & #4 pair, and very little or no pressure rise occurs across the refiner. For example, the pressure might rise from an inlet of 2.5 bars, to a casing pressure of about 4 bars, and then back to an outlet pressure of 2.3 bars. Experience has shown that in order to get uniform plate wear, it is necessary to have a pressure drop of about 0.2 – 0.3 bars across the refiner. Often this requires a relatively high flow rate through the refiner, and subsequent recirculation in order to achieve the proper net flow.

Because of the lack of symmetry in the hydraulics of the mono-flo refiner, it can often be very difficult to predict in advance what pattern will produce proper rotor balance for a given flow rate. And since precise balance will only occur at a specific flow rate for that fixed plate pattern, it is usually necessary to operate with a recycle flow to ensure balance over a wide range of net flow requirements.

One of the arguments favoring mono-flo operation is the fact that the flow is assured to be identical between the two disc pairs. Therefore, it remains only to be certain that the pressure distribution across the face of the #2 plate results in the same normal force as results from the pressure distribution across the #3 plate to ensure uniform refining.

In order to understand the potential for rotor imbalance in a mono-flo refiner, it is necessary to look more carefully at the flow and pressure conditions within the refiner plates. Figure 11 illustrates the pressure distribution acting across the face of the #2 plate in a mono-flo refiner. Two examples are shown, one for “hi flow” and one for “lo flow”.

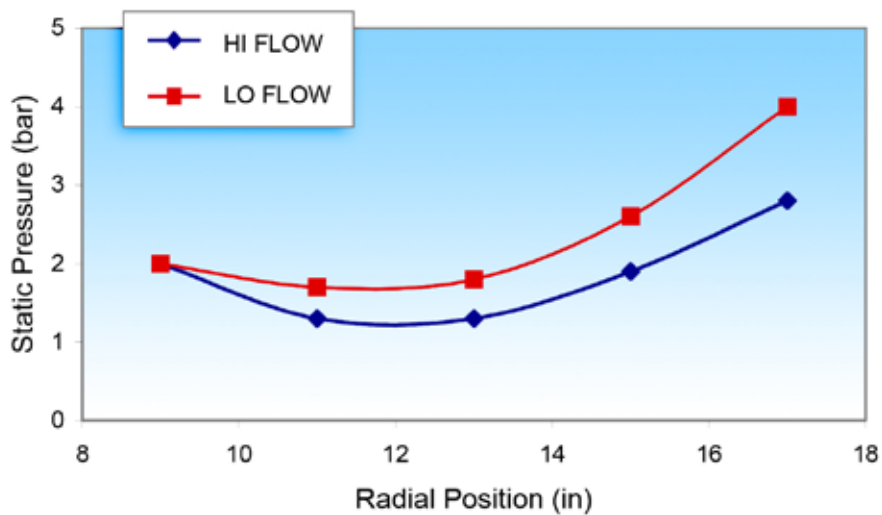

**Figure 11:** Pressure Distribution

The static pressure drops as flow enters the refiner at the ID due to a suction effect. The higher the flow, the higher the suction effect as we know from the NPSH requirements for centrifugal pumps. As the fluid is further accelerated outward toward the OD, the static pressure rises and reaches a maximum at the OD.

As we know from the analysis of a duo-flo refiner, increasing the bar height and the relative groove width on the rotor plate increases the flow capacity. For a given rotor plate configuration, an increase in bar height and/or relative groove width on the stator reduces the capacity by increasing “leak back”. Therefore, the casing pressure in a mono-flo refiner can be reduced by increasing the flow rate, by reducing the bar height on the #2 rotor plate, or by increasing the bar height on the #1 stator plate. Reducing the bar angle on the plate pattern can also reduce casing pressure somewhat. All of these factors will have the same general effect on the pressure distribution of Figure 11 as if the flow rate were increased.

In a mono-flo refiner, it is necessary to maintain sufficient pressure in the casing to overcome the outward pumping effect of the #3 rotor. This pumping effect can be similarly reduced by reducing the rotor bar height, increasing the stator bar height, or increasing the amount of negative pumping angle.

In general, changing bar angles is not an ideal way to control the hydraulics of a disc refiner regardless of the mode of flow. From the point of view of refined pulp quality, the optimum intersecting angle is fixed at around 45°. It is difficult to materially alter the hydraulic characteristics of a mono-flo refiner by changing bar angle without having an adverse affect on pulp quality. The most effective method of control is with recycle flow which permits the use of a variety of plate patterns and accommodates a wide variation in net process flow rate. The next best method to control the hydraulics is to control the bar height and the ratio of groove-width to bar-width of the #2 and #3 plates. In this way, hydraulic balance of the rotor can be achieved while maintaining the flow capacity of the refiner.

Under the proper hydraulic conditions in a mono-flo refiner, the pressure distribution acting on the #2 and #3 plate faces will be as shown in Figure 12. With the shallower distribution on the #3 plate and a modest pressure drop, the net force resulting from the mathematical integration of the two profiles will precisely cancel, resulting in a perfectly balanced rotor.

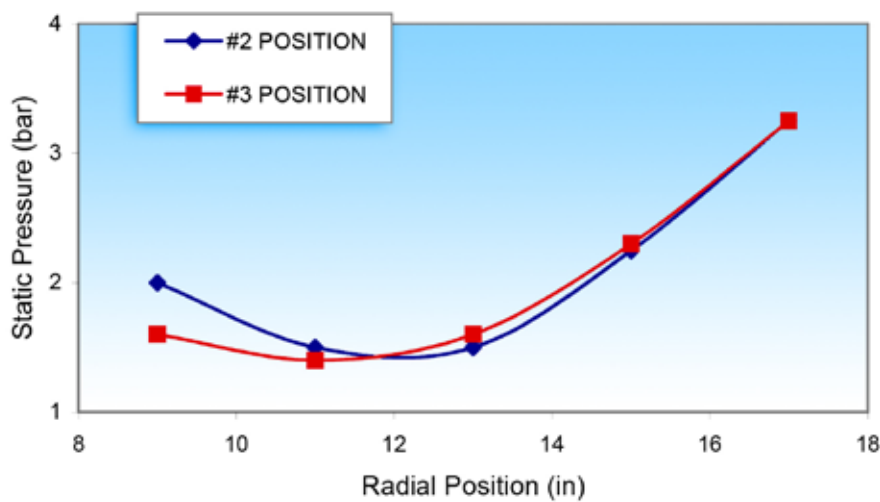

**Figure 12:** Pressure Distribution

While proper balance of a mono-flo refiner can be difficult in the absence of a recycle flow loop, it is possible to achieve acceptable operation by stepwise change in the bar-groove geometry of the refiner plates.

## Appendix C

### Case Study and Sample Calculations

A fine paper mill is refining bleached hardwood kraft under the following operating conditions:

- One 34" DD refiner with a 1000 hp/600 rpm motor
- 700 hp applied motor load
- 900 gpm flow with no recirculation
- 4% consistency
- 500 ml freeness target
- 34" cast plates with a 2.0,2.0,4.0 pattern
- 30 km/rev bar edge length

Use this information to calculate the no load power, net hpd/t, refining intensity and freeness change per hpd/t applied.

#### STEP 1 - Calculate no load power

$$NL = (102 * (RPM/100)^3 * (Diam/100)^{4.3}) * (2 * Groove Width / (Bar + Groove Width)) * (Groove Depth / 4)$$

Motor speed	600	rpm
Plate diameter	34	inches
Bar width	2.0	1/16 in
Groove width	2.0	1/16 in
Groove depth	4.0	1/16 in
<b>No Load =</b>	<b>213</b>	<b>hp</b>

#### STEP 2 – Calculate applied power

$$\text{Net Power} = \text{Applied Motor Load} - \text{No Load Power}$$

Applied power	700	hp
No load power	213	hp
<b>Net Power =</b>	<b>487</b>	<b>hp</b>

#### STEP 3 – Convert from hp to kW

$$\text{Net kW} = 0.7457 * \text{net hp} = 363 \text{ kW}$$



#### STEP 4 – Calculate throughput

Short Tons/Day = Gallons per Minute \* % Consistency \* 6

Flow	900	gpm
Consistency	0.04	
<b>Throughput =</b>	<b>216</b>	<b>t/d</b>

#### STEP 5 – Calculate net specific energy

Specific Energy = Net Power / Tons per Day

Net power	487	hp
Tons per day	216	t/d
<b>Specific Energy =</b>	<b>2.3</b>	<b>net hpd/t</b>

#### STEP 6 – Calculate Specific Edge Load (refining intensity)

Specific Edge Load (SEL) = Net kW / (Bar Edge Length \* Motor Speed \* 1 min / 60 s)

Net kW	363	kW
Bar edge length	30	km/rev
Speed	600	rpm
<b>Specific Edge Load =</b>	<b>1.2</b>	<b>Ws/m</b>

#### STEP 7 – Calculate the freeness drop achieved per hpd/t applied

$\Delta$  CSF/ hpd/t = (Inlet CSF – Outlet CSF) / net Specific Energy

Inlet CSF	625	ml
Outlet CSF	500	ml
Specific energy	2.3	hpd/t
<b><math>\Delta</math> CSF/ hpd/t =</b>	<b>55</b>	<b>ml / hpd/t</b> (60-100 ml is typical for HWD kraft)

**STEP 8 – Assess potential benefits of reduced periphery Finebar® plates with equal groove volume and twice the edge length.**

Reduced plate diameter	31	in
Bar width	1.0	1/16 in
Groove width	1.5	1/16 in
Groove depth	3.5	1/16 in
Bar edge length	59	km/rev
Motor speed	600	rpm

**New No Load = 150 hp** - a savings of 63 hp based on plates as new

**New SEL = 0.6 Ws/m** - in recommended SEL range for HWD of 0.3-0.8 Ws/m

**Annualized energy cost savings @\$0.045/kWh**

$$\begin{aligned} &= (63 \text{ hp} * 0.7457 \text{ kW/hp}) * (\$0.045/\text{kWh}) * (24 \text{ h/day}) * (365 \text{ days/yr}) \\ &= \$ 18,400 \end{aligned}$$

Note that additional energy savings would likely be realized from the improved efficiency achieved when refining hardwood kraft at low intensity.

\*\*\*\*\*

END